

January 2020
Edina Model Yacht
Club News Letter



**7499 FRANCE AVENUE SOUTH
EDINA, MN 55435**

January 2020 Membership Meeting and Other News

We have already had two great events to start off the year 2020 - the Board meeting and the January Membership meeting. Lots of great discussion for events this year at the Board meeting, and lots of great boats at the Membership meeting! Let's get started with a quick rundown of the Board meeting:

Board Meeting

- Treasurer's report: We started with \$1,442 in the bank on January 1, 2019, and finished with \$1,255 on December 31st. The main activity on the account is summarized as follows:
 - Income
 - Membership was 58, \$1,800 in dues
 - Donations for the tri-hull boat, \$150
 - Swap meet and other boat sales for items donated to the club, \$927
 - Sale of EMYC caps, \$156
 - Expenses
 - Website, \$214
 - Tri-Hull boat and battery, \$625
 - EMYC caps, \$264
 - New flags/rope for skipper area, \$138
 - Parade of Boats, \$575 (mostly Captain Jack)
 - Dry Dock Party, \$1,300

It was decided to not increase the club dues, which remain at \$30 individual, \$40 family.

The club has been more than fortunate to have had Larry Wheeler as Treasurer for many years. Recently, Larry has unfortunately made the difficult decision to relinquish the treasurer's position. Julia Moen has indicated her interest in taking over the treasurer responsibilities, which includes tracking membership. To assist Julia in this transition, and to be certain people are properly credited, we need to request that anyone that has pre-paid in 2019 for their 2020 dues complete the 2020 membership application form (which is attached) and indicate in the area of type of membership (individual or family) that you prepaid in 2019. I know I can rely on everyone's Scouts Honor on this one.

- Promotion: Hub Hobby is willing to put a sticker on their boat kits which would indicate that the EMYC is willing to give advice on building kits. Tim Crain has created a suggested content for the sticker:

Overwhelmed? - We can help!
The Edina Model Yacht Club has
Members that would be glad to help!
Email: help@emyc.org

Let me know anything you would like to add, change or any other suggestions for the sticker. To make this work we would add a new "Help" address to the website where someone would receive the email requests and put that person in touch with the right person in the club. That also means we need people that are willing to advise people that request help. Volunteers will need to indicate what phases of the build they are interested in supporting. Hold on for just a bit though until we secure the person that will be the recipient for the "Help" requests and who will organize the response.

- Website: In addition to the "Help" address there are some housekeeping items being addressed. No other changes to the website were suggested (except see Newsletters below).
- Newsletters: No changes to the newsletter except that the copies of the newsletters that are posted on the website will have the personal email addresses and phone numbers removed so that that information is not available to persons that scan the internet for nefarious purposes. Back issues have already had this information expunged.
- Club Events: All dates for known club events have been set and are included in the attached calendar of events. New for this year is the Breakfast Brunch that will kick off the year on Saturday, April 4th. The same day will see the first open-to-the-public sale of boats and other items. It was decided there will be a \$5 per person donation to the club to attend the Breakfast Brunch. This will help out with the expense until we determine what the actual interest/attendance in the brunch will be and the cost. We will re-evaluate this cost per person for future brunches assuming there is adequate interest to carry it forward. We are also requesting a name for this event to book-end with the Dry Dock Party. Suggestions are appreciated.

There are several possible new events that were discussed. One definite new event(s) is for the large sailboats. Gary Tschautscher has expressed his commitment to head up several events for these boats this year. The initial plan is to hold the events at the south pond. They will be non-competitive events and just for the purposes of enjoying sailing and seeing these wonderful boats on the water. Since sailing is completely dependent on the wind these events will be mostly spur of the moment. To facilitate this a new Google group will be created to facilitate communication with the boat owners/participants. More information on the formation of this group to follow.

Additional discussion included limited events for fast electrics, again this would likely happen at the south pond. Some fast-ish electrics are being renovated and it would be a fun event to get these boat owners together to enjoy the boats all together. There is already a Google group for fast electrics so if you would like to participate in these events get in touch with David Petrich (info@emyc.org). There were other suggestions including a poker run and in general we are always looking for ways to encourage members to get their boats on the water and have fun together.

- Dry Dock Party: I have not received any feedback from last year's party so we are assuming everyone was happy with the event and enjoyed themselves. The attendance held steady from previous years at about 50 persons. It was suggested that maybe we want to consider some other types of food or caterer simply for variety of food provided. Famous Dave's did an excellent job again this year. We had the same servers as last year as when they saw EMYC was on their calendar again both servers quickly signed up to work with Terry and the group. We need to know by June who we want to work with for the banquet so please let Terry know (info@emyc.org) if you would like to keep Famous Dave's for 2020 or look for something different. Tim Crain is getting some sample prices from several other restaurants that we can consider so there will be more information coming, but we really need to know from people initially if you would like to stay with Famous Dave's or go a different direction.

A change we did adopt is to move the entire schedule to one hour earlier. We felt this was necessary to accommodate many people wanting to end the evening just a bit sooner. This means that the reception will start at 4:30, dinner served at 5:30, and the program starting at 6:30. We also discussed changing the banquet to a lunch venue but decided to see how starting one hour earlier works out. A few years ago Jeff McCabe did an excellent presentation of the history of Centennial Lakes Park, which got a lot of very favorable response. So in addition to the excellent slide presentation that Todd puts together covering all the yearly events (boy I love seeing the year in review!) I would like to add a brief program that would be of interest to everyone that attends. I would appreciate any suggestions that people have for a short presentation that we could include in the program before the slide show.

- Other Discussion:
 - The cage storage area is getting pretty full of boats and just stuff, so after the spring sale we will have to take a serious look at tossing some things out, whether it is boats and/or other items and equipment that have been donated to the club and/or other items that have been in storage but not used in many years.
 - The Pelican boat needs to be cleaned up for sale this spring. Already the wood seating surfaces have been removed and are being cleaned and

refinished. Tim Crain and I have volunteered to clean up the hull in preparation of installing the reconditioned seats. Let me know if you would like to help Tim and myself out with what should be a fun task.

- I added a final item to the Board meeting agenda of “New Commodore”. I felt I had to bring this to the attention of the Board not because I was unwilling to continue serving as Commodore, but because in the founding of the club it was intended that the Commodore position would not be a long term position. I also think it is healthy for the club to have a change of leadership. The Board, and other members in attendance, indicated they would like to see me continue in the position so long as it has not become a burden to me, which it has not. However, I would like to seriously encourage anyone else in the club to give consideration to serving as Commodore. I would be more than happy to mentor someone as the new Commodore.

Now, on to the rest of the Membership Meeting!

You have certainly noticed that we have had quite a few really nice boats from our members come up for sale, refurbishment or just to find new homes. The Swap Meet is not closed to the public but it is also not specifically advertised as a public event to give club members the first opportunity to purchase boats and equipment. The spring sale is intended offer up boats to the public to further help facilitate placing boats for our members. In the spirit of first look a few more boats have been brought to my attention to present to the club membership. The first comes from Bob Lundberg in Duluth who purchased a model boat from an estate sale.



The boat is the “Nabila” and is about 50 inches long. Bob reports that the boat has the older style Graupner electronics and appears to have been a ready - built boat, not a kit. The lights work and the blades on the helicopter are also functional. Bob has other pictures and articles that were written about the boat, which he also shared with me. Let me know if you are interested and I get you the additional information and can put you in touch with Bob.

The next boats will be familiar to many as they are from Bill Uhl’s workshop. Many of us can say that we have too many boats and Bill has decided some of his need new homes. We all know Bill as a gifted builder of boats and all are created in Bill’s own distinct style. His boats are absolutely some of my favorite boats in the club. Here are the three that are looking for homes:





I can, of course, put you in touch with Bill.

I am assuming all of these boats that are not placed by April will be included in the public sale.

Show and Tell

Whew!!! What a load of boats for the first meeting. Above I mentioned club members getting first crack at boats, well that is further refined for first crack at boats for those that attend the meetings - see below for details. Here we go in order of presentation:

- Tim Crain, ever the prolific boat builder, brought several boats! We had no idea of how deep his model building affliction is. First up was an update on the Calypso under construction:



Next an update on the Whale boat:



And finally, look at this offering of canoes and other boats that by reason of needing more room at home all found new homes with those that attended the meeting.



A huge thanks to Tim for bringing his boats in to show us the progress and for sending many happy members home with new boats.

Next was Kevin Waldo and Mark Nichols who are working on one of the boats I thought had the least chance of being updated.



This is an air boat that formerly had a gas airplane engine on top - now removed. Kevin and Mark are transforming it into an inboard electric.

Kevin also brought his latest figure, Farrah Fawcett, who will be riding shot gun with Svengoolie this summer.



What!! You thought I was going to include a picture of the real Farrah Fawcett!?!?

John Bishop and Dick Walker have been collaborating on a Chris Craft Corvette. This boat was in true derelict condition when it was adopted by Jim Penoyer sometime ago. Dick, being the club resident Corvette expert, contacted Jim to see what he was going to do with the boat, which Jim replied that the boat's future was uncertain and a deal was struck to transfer renovation responsibilities to Dick. This was a good thing as we all know Dick knows these boats inside and out. Casting new metal parts, complete and partial replacement of structure and decking, new paint and finishes and the boat was ready for John Bishop's touch with the electronics. John is describing how important it is to, firstly, build the boat so that you have great access to everything under the deck, all running gear and electronics.



John also strongly recommends doing a wiring diagram to make it easier in the future when something goes wrong and you need to figure out how it was supposed to work in the first place.

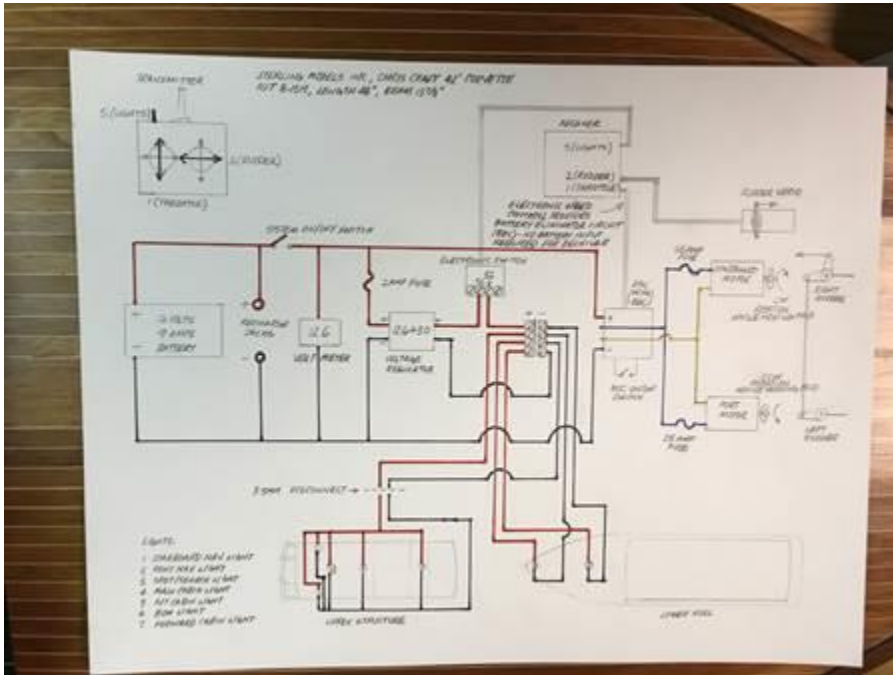

Beautiful work all around by both! That is what you call team work.

Mike Corbett, another prolific boat builder who's willingness to share his builds with the club is much appreciated, brought a very interesting boat that is a bit of history and shows small packages are also great. Actually two of the same boats since the first did not quite end up as Mike wanted, so a second, improved design, was built. This is a Keelcraft boat originally offered in the 50's to 70's. They were not RC at the time, but miniature electronics makes this possible now.



Doug Houser brought in a boat that he needed help with attending to a leak that has not been cured or easy to identify. Unfortunately the suggestions/direction from the group was not good news so I hope we get a good report of the “fix” at a future meeting, no matter how painful it was to address.



The meeting was getting long with all the boats that came in, but Gary Tschautascher gave a nice presentation and discussion about 3D printers in general, and his 3D printer and printing experiences in particular.



I apologize that I did not get a good picture of the items Gary brought that he had printed, but for additional photos and information on Gary’s presentation and all

the other presenters at the meeting I highly recommend that you go to Facebook and see the 51 photos that Richard Dahlquist posted. A very good description is included with the photos.

3D printing is definitely going to be a significant part of our and many other hobbies in the future. Right now one of the leading hobby groups using 3D printing is those doing model tanks. You may remember at a Parade of Boats a few years ago Mike Ross had a friend who brought and displayed a model tank that was built completely from 3D printed parts. Mike is going to contact this person to see if he would be willing to give us a presentation of his experience with 3D printing at a future meeting.

Next meeting is February 18th. I hope to see you there!

John Bertelsen
Commodore
Edina Model Yacht Club

www.emyc.org
info@emyc.org

